



It's no secret that high launch and low spin maximize driver distance, but some players think that only TOUR pros can benefit from lofting up. This is simply not true. By lofting up, you can generate serious distance gains regardless of swing speed with SLDR S, which has low and forward CG properties, along with a sliding weight that assists shot shape.

**BENOIT VINCENT**  
VICE PRESIDENT  
RESEARCH AND DEVELOPMENT

## SLDR Distance For All

- ▶ Stunning modern-classic shape with satin silver crown and black button-back for easy alignment.
- ▶ Low-Forward CG promotes high launch, fast ball speed and low spin for exceptional distance.
- ▶ Easy and intuitive SLDR sliding weight promotes up to 30 yards of shot shape adjustment.
- ▶ Fujikura Speeder 57 shaft blends light weight with great feel and playability.



### SHAFT

FUJIKURA SPEEDER 57 - X, S, R, M  
FUJIKURA SPEEDER 47 - L

### GRIP

TM 360 SILVER - 54g  
TM 360 SILVER LADIES - 41g

HEAD	LOFT	LH	LIE	VOLUME	LENGTH M	SW M	LENGTH W	SW W
SLDR S DRIVER	10°	YES	61	460cc	45.5"	D4	44.5"	D2
SLDR S DRIVER	12°	YES	61	460cc	45.5"	D4	44.5"	D2
SLDR S DRIVER	14°	YES	61	460cc	45.5"	D4	44.5"	D2
SLDR S DRIVER	16°	YES	61	460cc	45.5"	D4	44.5"	D2

CUSTOM OPTIONS AVAILABLE | TP SHAFT OPTIONS AVAILABLE (RH ONLY)



“ Golfers were asking for an SLDR fairway that has a lower and more forgiving profile. The SLDR S fairway has a shallower face and larger head size engineered to deliver distance and playability. Combine that with a stunning satin silver crown with black button back for easy alignment and you have a club that inspires confidence and great results.

**TODD BEACH**  
VICE PRESIDENT  
PRODUCT DEVELOPMENT

## SLDR Distance For All

- ▶ Low profile head design with shallow face promotes easy launch for outstanding playability.
- ▶ Speed Pocket design promotes fast ball speed for longer distance.
- ▶ Low-forward CG promotes fast ball speed and low spin for optimal launch conditions
- ▶ Satin silver crown with black button-back promotes easy alignment.
- ▶ Fujikura shaft designed specifically for a fairway wood to promote long distance with controlled accuracy.

### LOW AND FORWARD CG PROMOTES HIGH LAUNCH WITH LOWER SPIN

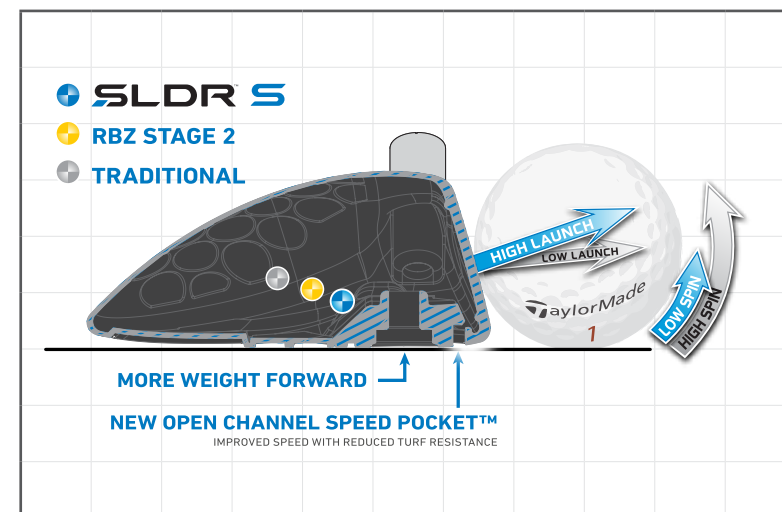

#### SHAFT

FUJIKURA SPEEDER 65 – X, S, R, M  
FUJIKURA SPEEDER 47 – L

#### GRIP

TM 360 SILVER – 55g  
TM 360 SILVER LADIES – 40g

HEAD	NUM	LOFT	LH	LIE	VOLUME	LENGTH M	SW M	LENGTH W	SW W
SLDR S FAIRWAY	3	15°	YES	57	165cc	43.25"	D3	42.25"	C9
SLDR S FAIRWAY	3HL	17°	NO	57	165cc	43.25"	D3	42.25"	C9
SLDR S FAIRWAY	5	19°	YES	57.5	145cc	42.25"	D3	41.25"	C9
SLDR S FAIRWAY	5HL	21°	NO	58	145cc	42.25"	D3	41.25"	C9
SLDR S FAIRWAY	7	23	NO	58	135	41.75	D3	40.75	C9

CUSTOM OPTIONS AVAILABLE | [TP SHAFT OPTIONS AVAILABLE \(RH ONLY\)](#)



“ Golfers were asking for an SLDR Rescue that has a lower and more forgiving profile. The SLDR S Rescue has a shallower face and larger head size engineered to deliver distance and playability. Combine that with a stunning matte silver crown with black button back for alignment and you have a great looking rescue that is long and easy to hit.

**ROB RIGG**  
METALWOODS CATEGORY MANAGER

## SLDR Distance For All

- ▶ Low profile head design with shallow face promotes easy launch for outstanding playability.
- ▶ Speed Pocket design promotes fast ball speed for longer distance.
- ▶ Low-forward CG promotes fast ball speed and low spin for optimal launch conditions.
- ▶ Satin silver crown with black button-back promotes easy alignment.
- ▶ Fujikura shaft designed specifically for a Rescue promotes long distance with controlled accuracy.

### SHALLOW FACE FOR INCREASED PLAYABILITY

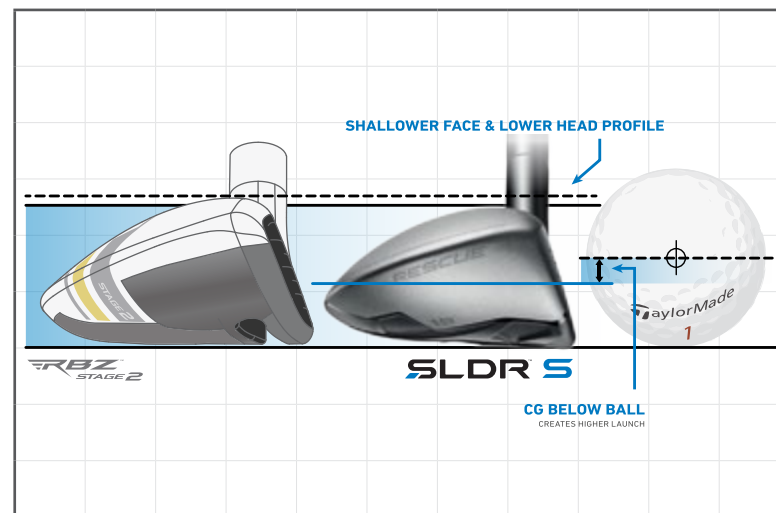

#### SHAFT

FUJIKURA SPEEDER 72h – S, R, M  
FUJIKURA SPEEDER 62h – L

#### GRIP

TM 360 SILVER – 54g  
TM 360 SILVER LADIES – 41g

HEAD	CLUB	LOFT	LH	LIE	VOLUME	LENGTH M	SW M	LENGTH W	SW W
SLDR S RESCUE	3	19°	YES	58	120cc	40.75"	D2	40.0"	C7
SLDR S RESCUE	4	21°	YES	58.5	125cc	40.25"	D2	39.5"	C7
SLDR S RESCUE	5	25°	NO	59	125cc	39.75"	D2	39.0"	C7
SLDR S RESCUE	6	28°	NO	59.5	125cc	39.25"	D2	38.5"	C7

CUSTOM OPTIONS AVAILABLE